

# 2 1/2" BORE STAINLESS STEEL CYLINDER



## SDR-40-□-□

Double Acting



**Mount:** Stud      **Standard Stroke Lengths:** 1", 2", 3", 4", 5", 6"  
**Type:** Rotating Rod      **Maximum Stroke:** 39"  
**Options:** C, F, R, M, W, V, P6, P7, P8, S, N

**Bumpers are standard**  
 For M option add 0.312

For S option add 0.375

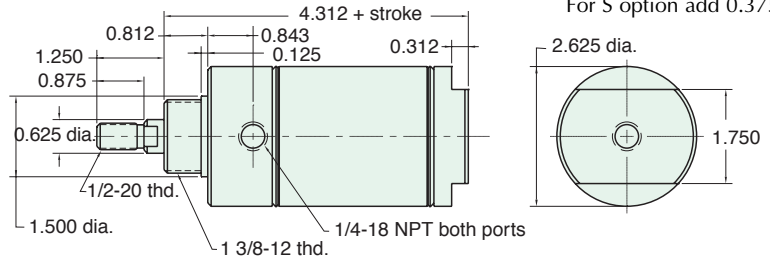

Nut included, but not shown on drawing

For C, F, & R options use side ported rear head

## UDR-40-□-□

Double Acting



**Mount:** Universal      **Standard Stroke Lengths:** 1", 2", 3", 4", 5", 6", 7", 8", 10", 12"  
**Type:** Rotating Rod      **Maximum Stroke:** 38"  
**Options:** C, F, R, M, W, V, P2, P3, P4, P5, P6, P7, P8, N

**Bumpers are standard**

For M option add 0.312

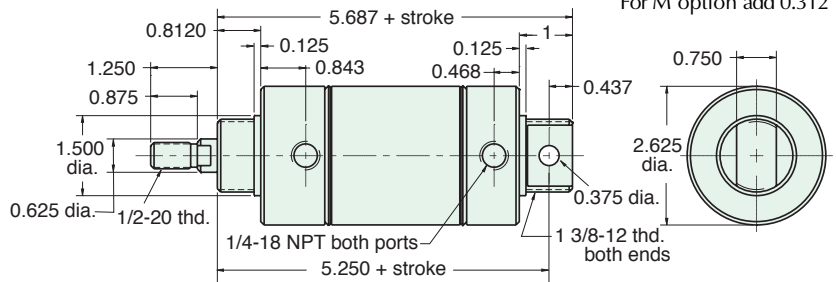

Furnished without nut(s). See Chart on Page 56.

## SDD-40-□-□

Double Acting



**Mount:** Stud      **Standard Stroke Lengths:** 1", 2", 3", 4", 5", 6", 8", 10", 12"  
**Type:** Double Rod      **Maximum Stroke:** 18"  
**Options:** C, F, M, W, V, P6, P7, P8, N

**Bumpers are standard**

For M option add 0.312

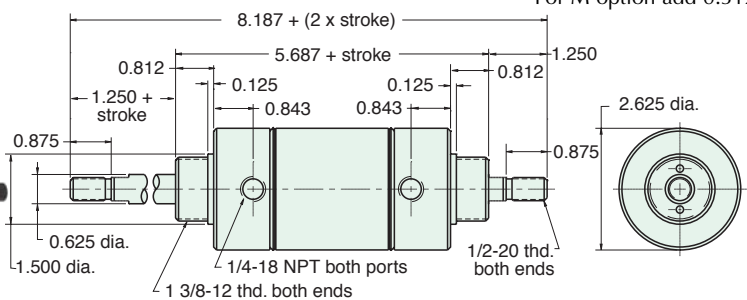

Nut included, but not shown on drawing